

# FRL SERVICE UNITS

DESCRIPTION		PRESSURE RANGE max. bar	CONNECTION thread	DEVICE	PAGE
made of plastic, 2- and 3-part	C2, C3	0 ... 8 / 12	G $\frac{1}{4}$ - G1	C2, C3	<b>19.03</b>
assembly diagrams	C2, C3			C35 ... C95	<b>19.04</b>
switch-on and soft start valve	C2, C3		G $\frac{1}{4}$ - G $\frac{3}{4}$	A0, S0, V0	<b>19.05</b>
made of brass, 2- and 3-part		0.3 ... 3 / 15	G $\frac{1}{4}$ and G $\frac{1}{2}$	CM	<b>19.06</b>
„Maxi“-Series, made of metal, robust, 2- and 3-part		0.2 ... 4 / 17	G $\frac{1}{2}$ - G1	C20, C21	<b>19.07</b>
Series „D“, made of alu, 2-part		0.3 ... 3 / 15	G $\frac{1}{8}$ - G2	CD2	<b>19.08</b>
Series „D“, made of alu, 3-part		0.3 ... 3 / 15	G $\frac{1}{8}$ - G2	CD3	<b>19.09</b>
„Standard“-Series, robust		0.2 ... 4 / 17	G $\frac{3}{4}$ - G2	C630	<b>19.10</b>
drain valves		max. 21		SA, RK	<b>19.11</b>
hose rupture valves, aluminium/stainless steel		max. 18	G $\frac{1}{4}$ - G2	281	<b>19.12</b>



# 19

# ASSEMBLY DIAGRAMS FOR PLASTIC FRL SERVICE UNITS C2/C3

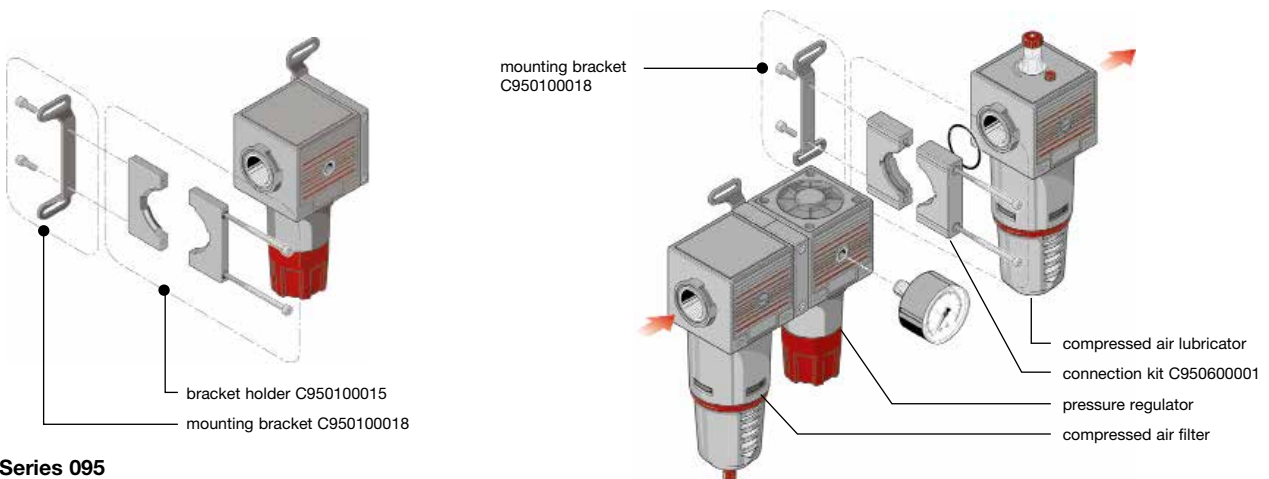
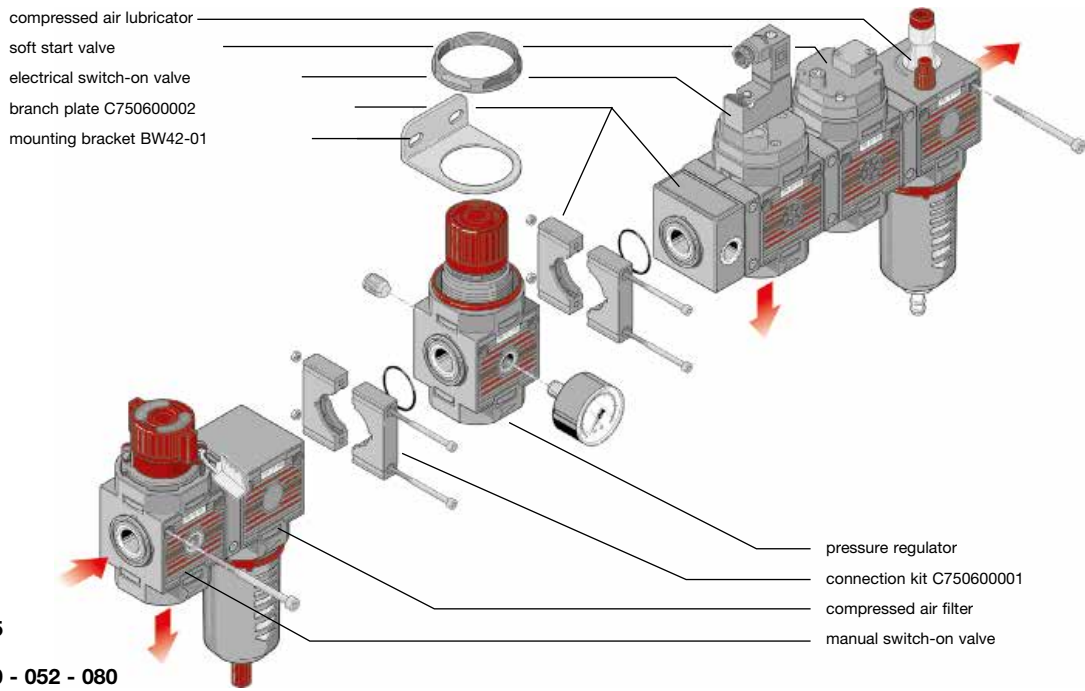
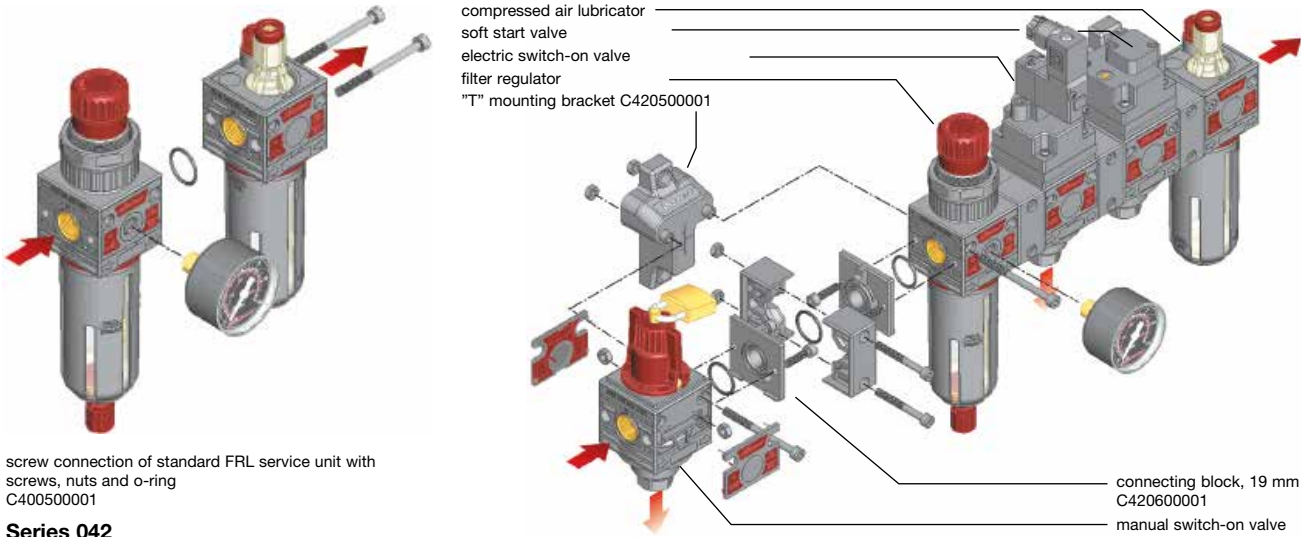

<b>Description</b>	Made up of modular components which can be combined to form compact units. Switch-on and soft start valves available as additional modules.		
<b>Media</b>	compressed air or non-corrosive gases		
<b>Supply pressure</b>	max. 12.5 bar, max. 7 bar at lubricator with oil level indicator, max. 16 bar for Series 042		
<b>Gauge port</b>	G $\frac{1}{8}$ or G $\frac{1}{4}$ at series 095, on both sides of the body, one screw plug supplied		
<b>Filter element</b>	20 $\mu$ m, optionally 5 $\mu$ m, made of sintered polyethylene		
<b>Bowl</b>	plastic version with bayonet catch, series 042 with connection thread		
<b>Drain</b>	manual drain with semiautomatic drain, optionally automatic drain		
<b>Oil refilling</b>	optionally with semiautomatic oil refilling without need to interrupt operation		
<b>Oil level indicator</b>	If the oil level falls below the limit value, a float will close a signal contact.		
<b>Temperature range</b>	0 °C to 50 °C / 32 °F to 122 °F	Voltage:	max. 115 V
<b>Material</b>	Body: nylon, POM at series 042	Inner valve:	brass
	Bowl: polyamide	Thread insert:	brass
	Elastomer: NBR/Buna-N		

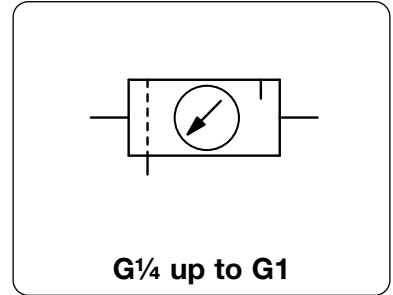

Dimensions				Combination	Bowl	Flow	Connection	Order	
A	B	C	K	consist	design	rate	thread	number	B*
mm	mm	mm	mm	of	made of / with	m $^3$ /h*1	l/min*1	G	

FRL unit, 2-part					P $_1$ : max. 12.5 / 16 bar, P $_2$ : 0...8 bar, 20 $\mu$ m, semiautomatic drain, with pressure gauge			C2	
84	208	126	-	B+L042	plastic/	59	980	G $\frac{1}{4}$	C242-02HC
115	239	148	126	B+L050	bowl guard	84	1400	G $\frac{3}{8}$	C250-03HC
115	239	148	126	B+L052		90	1500	G $\frac{1}{2}$	C252-04HC
139	276	173	151	B+L075		132	2200	G $\frac{1}{2}$	C275-04HC
212	276	173	-	B+L080		138	2300	G $\frac{3}{4}$	C280-06HC
210	415	237	230	B+L095		480	8000	G1	C295-08HC



FRL unit, 3-part					P $_1$ : max. 12.5 / 16 bar, P $_2$ : 0...8 bar, 20 $\mu$ m, semiautomatic drain, with pressure gauge			C3	
126	208	126	-	F+R+L042	plastic/	59	980	G $\frac{1}{4}$	C342-02HC
178	239	148	189	F+R+L050	bowl guard	84	1100	G $\frac{3}{8}$	C350-03HC
178	239	148	189	F+R+L052		90	1500	G $\frac{1}{2}$	C352-04HC
215	276	173	227	F+R+L075		132	2200	G $\frac{1}{2}$	C375-04HC
288	276	173	-	F+R+L080		138	2300	G $\frac{3}{4}$	C380-06HC
325	411	237	345	F+R+L095		480	8000	G1	C395-08HC



**Special options, add the appropriate letter**

5 $\mu$ m filter element	C...-0.G.
0...12 bar regulating range	C...-0...D
automatic drain	C...-0...R
semiautomatic oil refilling	C...-0...X65
oil level indicator	C...-0...X66

**Accessories, enclosed**

mounting bracket	made of steel, mounting nut at the device	for C.42	<b>BW30-01</b>
		for C.50 to C.80	<b>BW42-01</b>
set of brackets	made of steel, mounting nut at the device	for C.95	<b>BW00-02</b>

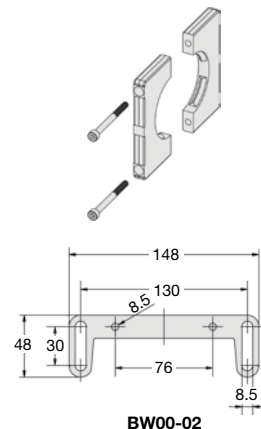
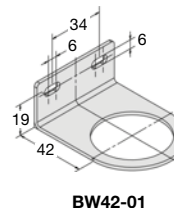
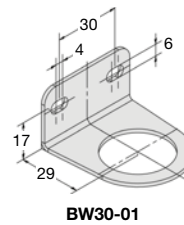
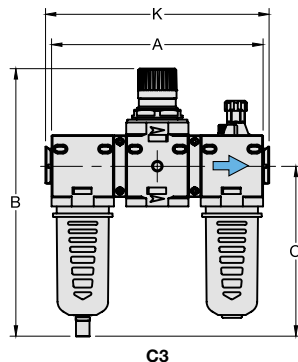
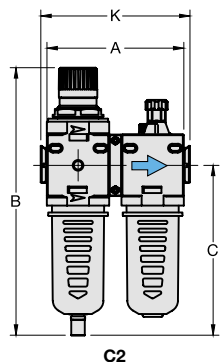

\*1 at 10 bar supply pressure, 6 bar outlet pressure and 1 bar pressure drop  
 \*2 04 = 0...4 bar, 10 = 0...10 bar, 16 = 0...16 bar

Further details: see chapter for single devices

PDF CAD  
www.aircom.net

\* Product group



Order example:  
C242-02HC

<b>Connection kit</b>	With this interlocking kit, two compressed air instruments can be connected to one another without need for double nipples. This makes possible very compact layouts.
C35 :	<ul style="list-style-type: none"> <li>Mounting using rotary clip and two o-rings. These allow regulators to be connected to other regulators or filters.</li> </ul>
C40 :	<ul style="list-style-type: none"> <li>Instruments are connected to each other using screws, nuts and o-ring;</li> <li>alternatively, a segmented connecting block can be used for instrument connection.</li> </ul>
C50 :	<ul style="list-style-type: none"> <li>Instrument connection by means of a two-part connecting block.</li> </ul>
<b>Branch plate</b>	
C40 :	<ul style="list-style-type: none"> <li>Branch plate with compressed air connection port G<math>\frac{1}{8}</math> or G<math>\frac{1}{4}</math> or both outlet plates.</li> <li>Supply plate for two pressure regulators through port G<math>\frac{1}{4}</math>.</li> </ul>
C50 :	<ul style="list-style-type: none"> <li>Branch plate with compressed air connection G<math>\frac{1}{4}</math>.</li> </ul> Port installation of the branch plate is only possible using connecting blocks.

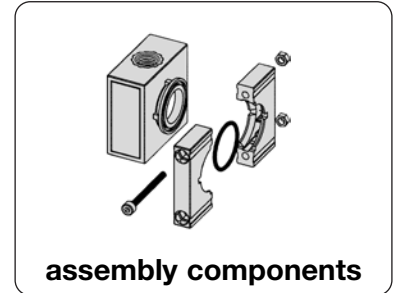

Description	Connection of instruments	for series	Order number
-------------	---------------------------	------------	--------------

Connection kit	for connecting separate instruments	C...	
rotary clips with two o-rings screws, nuts and o-ring	R+F or R+R or F+F	35	<b>C350100018</b>
	F+R+L or P+B+L	42	<b>C400500001</b>
	B+L	42	<b>C400600001</b>
	F+L or F+F	42	<b>C400700001</b>
connection kit	for any two instruments	42	<b>C420600001</b>
		50 / 52	<b>C500600001</b>
		75	<b>C750600001</b>
		80	<b>C800600004</b>
		95	<b>C950600001</b>



Branch plate	with compressed air connection port	C...	
outlet G $\frac{1}{8}$		42	<b>C400500102</b>
outlet G $\frac{1}{4}$		42	<b>C400500108</b>
outlet G $\frac{1}{8}$ and G $\frac{1}{4}$		42	<b>C400500103</b>
outlet G $\frac{1}{8}$ and G $\frac{1}{4}$	with connection kit	42	<b>C420500003</b>
supply G $\frac{1}{4}$ for two regulators		42	<b>C400500111</b>
outlet G $\frac{1}{4}$		50 / 52	<b>C500500003</b>
outlet G $\frac{1}{4}$		75	<b>C750600002</b>
outlet G $\frac{1}{4}$		80	<b>C800600005</b>

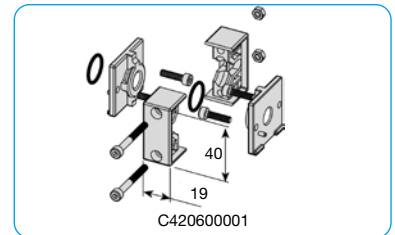

Mounting material			C...
mounting bracket		for G $\frac{1}{4}$	<b>BW30-01</b>
mounting bracket		for G $\frac{3}{8}$ to G $\frac{1}{2}$	<b>BW42-01</b>
wall mounting		for G $\frac{1}{4}$	<b>C420500001</b>
wall mounting		for G1	<b>C950100018</b>
bracket holder	required in absence of C9506	for G1	<b>C950100015</b>

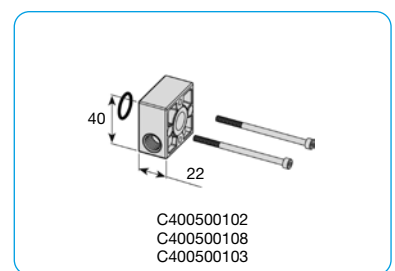
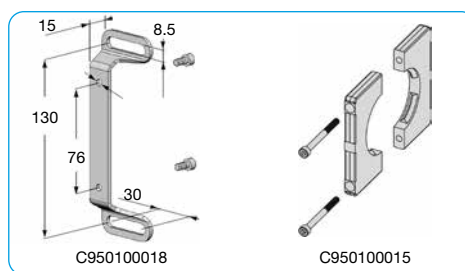
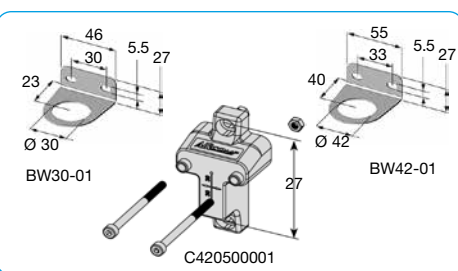
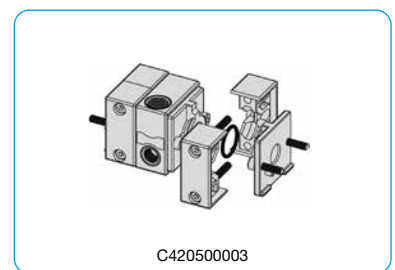
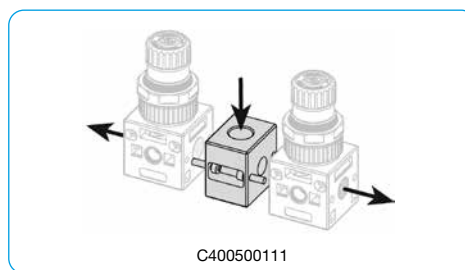
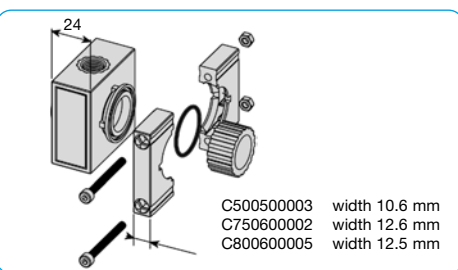
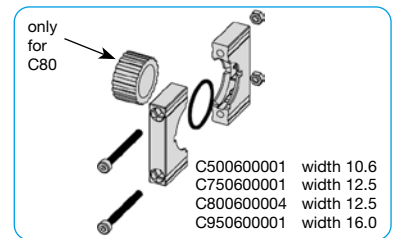

FRL units  
19

### Manual switch-on

Manual switch-on/off valve which relieves at switch-off. Tapped exhaust with connection thread G $\frac{1}{8}$  or valve G $\frac{1}{4}$ . Valve can be protected from unauthorised tampering by provided padlock. Wall mounting is possible through two drilled holes in the body. Maximum supply pressure is 15 bar.

### Electric switch-on valve

The electrically-operated 3-port/2-way valve switches the air flow on or off. As standard, it is supplied with a miniature valve or alternatively with a CNOMO valve and can be operated purely in a pneumatic way as option. Wall mounting is possible through two drilled holes in the body. Tapped exhaust with connection thread G $\frac{1}{8}$  or G $\frac{1}{4}$ . Maximum supply pressure is 3 to 10 bar.

### Soft start valve

The soft start valve slowly pressurizes the system and switches over to full scale operation when 60% of the nominal pressure is reached. The pressure raising period can be set by an adjusting screw on top of the valve. Wall mounting is possible through two drilled holes in the body. Maximum supply pressure is 3 to 10 bar.

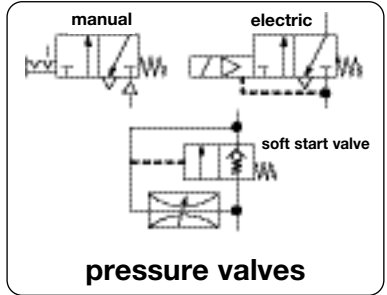

pressure valves

Dimensions			Description	Exhaust port	Flow rate		Connection thread	Order number
A	B	C			m <sup>3</sup> /h*1	l/min*1		
mm	mm	mm		G			G	

### Manual 3-port/2-way valve

supply pressure max. 15 bar, including padlock

### V0

42	110	45	manual switch-on	G $\frac{1}{8}$	96	1600	G $\frac{1}{4}$	<b>V042-02</b>
63	121	36	and switch-off of the	G $\frac{1}{4}$	156	2600	G $\frac{3}{8}$	<b>V050-03</b>
63	121	36	compressed air circuit	G $\frac{1}{4}$	162	2700	G $\frac{1}{2}$	<b>V052-04</b>
75	138	42		G $\frac{1}{4}$	186	3100	G $\frac{1}{2}$	<b>V075-04</b>
137	138	42		G $\frac{1}{4}$	192	3200	G $\frac{3}{4}$	<b>V080-06</b>

### Electric 3-port/2-way valve

24 V DC, 2 W, supply pressure 3...10 bar

### S0

42	143	42	electric switch-on	G $\frac{1}{8}$	96	1600	G $\frac{1}{4}$	<b>S042-02</b>
63	145	52	and switch-off of the	G $\frac{1}{4}$	156	2600	G $\frac{3}{8}$	<b>S050-03</b>
63	145	52	compressed air circuit	G $\frac{1}{4}$	162	2700	G $\frac{1}{2}$	<b>S052-04</b>
75	154	63		G $\frac{1}{4}$	186	3100	G $\frac{1}{2}$	<b>S075-04</b>
137	154	63		G $\frac{1}{4}$	192	3200	G $\frac{3}{4}$	<b>S080-06</b>

### Soft start valve

supply pressure 3...10 bar

### A0

42	105	42	slow pressurizing of the		96	1600	G $\frac{1}{4}$	<b>A042-02</b>
63	108	52	pneumatic plant,		156	2600	G $\frac{3}{8}$	<b>A050-03</b>
63	108	52	delay time adjustable		162	2700	G $\frac{1}{2}$	<b>A052-04</b>
75	117	63			186	3100	G $\frac{1}{2}$	<b>A075-04</b>
137	117	63			192	3200	G $\frac{3}{4}$	<b>A080-06</b>

### Special options, add the appropriate letter

<b>24 V AC, 2 W</b>	input supply voltage	for S0	S0...0.X
<b>115 V AC, 1 W</b>	input supply voltage	for S0	S0...0.Y
<b>230 V AC, 1 W</b>	input supply voltage	for S0	S0...0.Z
<b>pneumatic control</b>	C402600014, instead of electrical operation	for S0	S0...0.P



V052 manual switch-on valve



S052 electric switch-on valve



A052 soft start valve

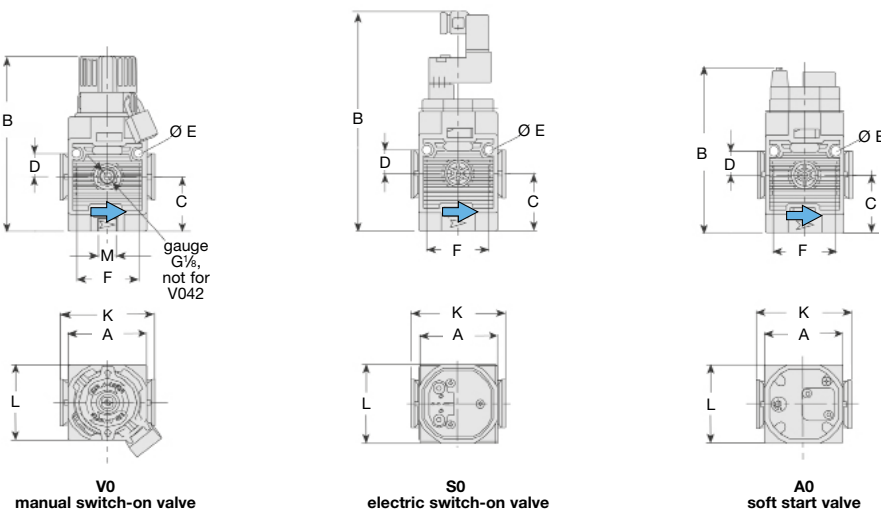

\*1 at 10 bar supply pressure and 1 bar pressure drop

\* Product group



<b>Description</b>	Extremely robust FRL service unit made of brass.
<b>Media</b>	compressed air, non-corrosive gases or liquids
<b>Supply pressure</b>	max. 50 bar at CM2, max. 30 bar at CM3, optionally max. 50 bar (all without drain)
<b>Adjustment</b>	by black plastic knob at CM.-02, by T-handle with locknut at CM.-04
<b>Gauge port</b>	G $\frac{1}{4}$ on both sides of the body, one screw plug supplied
<b>Filter element</b>	50 $\mu$ m, optionally 5 $\mu$ m, made of stainless steel
<b>Bowl</b>	stainless steel version without sight glass
<b>Drainage</b>	screw plug as standard, optionally manual drain (max. 30 bar) or automatic drain (max. 16 bar)
<b>Temperature range</b>	0 °C to 80 °C / 32 °F to 176 °F FKM 0 °C to 130 °C / 32 °F to 212 °F high temperature version for appropriately conditioned compressed air down to -20 °C / -4 °F
<b>Material</b>	Body: brass Bowl: stainless steel 316L / 1.4404 at G $\frac{1}{8}$ to G1, brass at G $\frac{1}{2}$ and G2 Elastomer: FKM optionally EPDM Knob: plastic at sizes G $\frac{1}{4}$ , brass at G $\frac{1}{2}$ Inner valve: brass and plastic (not at option X54)

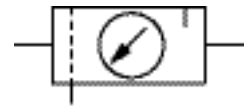

**G $\frac{1}{8}$  and G $\frac{1}{2}$ , max. 50 bar  
-20 to 130 °C / -40 to 266 °F**

Dimensions			Combination consisting of	Bowl design made of	Flow rate		Connection thread G	Order number
A	B	C			m $^3$ /h*1	l/min*1		

FRL unit, 2-part				P $_1$ : max. 50 bar, screw plug,	P $_2$ : 0.5...8 bar, relieving,	50 $\mu$ m, with pressure gauge	CM2	
138	220	123	BM+LM	stainless steel	51	850	G $\frac{1}{4}$	CM2-02
168	247	127			138	2 300	G $\frac{1}{2}$	CM2-04



CM2-04

FRL unit, 3-part				P $_1$ : max. 30 bar, screw plug,	P $_2$ : 0.5...8 bar, relieving,	50 $\mu$ m, with pressure gauge	CM3	
212	173	129	FM+R120+LM	stainless steel	51	850	G $\frac{1}{4}$	CM3-02
256	175	130			138	2300	G $\frac{1}{2}$	CM3-04



CM3-02

### Special options, add the appropriate letter

5 $\mu$ m filter element		CM . . . G
0.2... 3 bar pressure range		CM . . . B
1 ...15 bar pressure range	P $_1$ max. 50 bar	CM . . . D
manual drain	max. 30 bar	CM . . . H
automatic drain	made of stainless steel, max. 16 bar	CM . . . R
up to 130 °C / 266 °F	high temperature version	CM . . . X54
flange connection	see chapter for stainless steel devices / flanges	CM . . . F.

### Accessories, enclosed

mounting bracket	made of stainless steel	for G $\frac{1}{4}$	BW35-01S
mounting nut			M35x1,5S
mounting bracket	made of stainless steel	for G $\frac{1}{2}$	BW50-01S
mounting nut			M50x1,5S

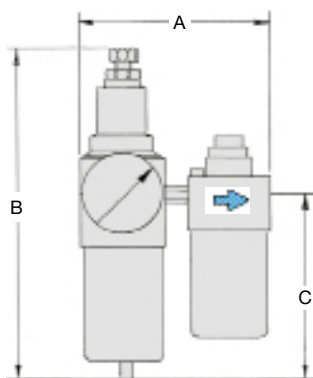

CM2-0. .H

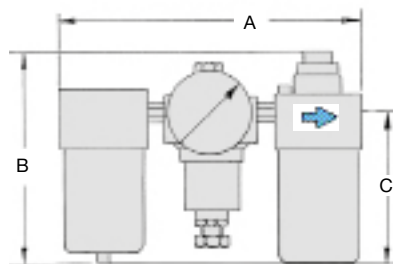

CM3-0. .H

\*1 at 7 bar supply pressure, 6 bar outlet pressure and 1 bar pressure drop

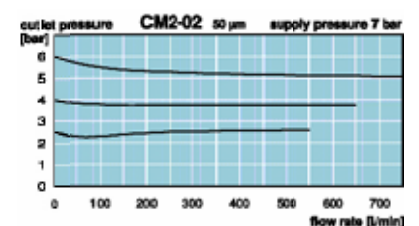
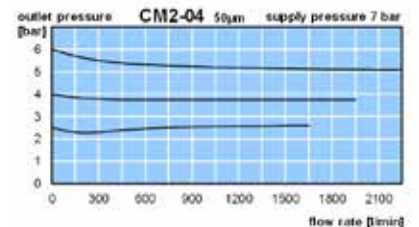

Further details: see chapter for single devices  
Spare parts: see separate spare parts list

PDF CAD  
www.aircom.net

Order example:  
CM2-02

<b>Description</b>	"Maxi" FRL service units with pressure gauge are of modular design with exchangeable insert kits and have a high flow rate. All "maxi" instruments are easy to take out of fixed piping by simply removing the two fastening bolts on the insert kits.	
<b>Media</b>	compressed air or non-corrosive gases	
<b>Supply pressure</b>	max. 17 bar	
<b>Adjustment</b>	by plastic knob with snap-lock at C20,	by T-handle with locknut at C21
<b>Relieving function</b>	relieving, optionally non-relieving	<b>Filter element</b> 40 µm, optionally 5 µm, made of polypropylene
<b>Gauge port</b>	G¼ on both sides of the body	<b>Bowl</b> metal version with sight glass
<b>Drainage</b>	manual drain as standard,	optionally automatic drain or semiautomatic drain for max. 12 bar
<b>Temperature range</b>	0 °C to 70 °C / 32 °F to 158 °F	
	0 °C to 50 °C / 32 °F to 122 °F for automatic	or semiautomatic drain version
<b>Material</b>	Body: zinc die-cast	Spring cage: zinc die-cast
	Knob (C20): glass fibre-reinforced plastic	T-handle (C21): steel
	Bowl: zinc die-cast	Sight glass: polyurethane
	Elastomer: NBR/Buna-N	Inner valve: brass and plastic

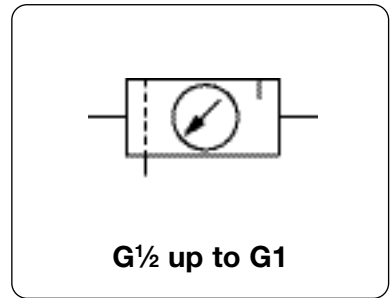

Dimensions			Combination consisting of	Bowl design made of / with	Flow rate		Connection thread G	Order number
A	B	C			m³/h*1	l/min*1		

FRL unit, 2-part				P1: max. 17 bar, P2: 0.3...9 bar, 40 µm, manual drain, relieving, with pressure gauge			C20	
178	289	175	B+L20	metal / sight glass	276	4600	G½	C20-04BL-W
203	289	175	B+L20	metal / sight glass	276	4600	G½	C20-04BL-W
					390	6500	G¾	C20-06BL-W
					402	6700	G1	C20-08BL-W



FRL unit, 3-part				P1: max. 17 bar, P2: 0.3...9 bar, 40 µm, manual drain, relieving, with pressure gauge			C20	
270	226	171	F+R+L20	metal / sight glass	102	1700	G¼	C20-02FRL-W
					174	2900	G¾	C20-03FRL-W
					276	4600	G½	C20-04FRL-W
292	226	171	F+R+L20	metal / sight glass	390	6500	G¾	C20-06FRL-W
					402	6700	G1	C20-08FRL-W



**Special options, add the appropriate letter**

T-handle	including locknut	C21-0 . . . . -W
5 µm filter element		C20-0 . . . . -WG
NPT	connection thread	C20-0 . . . . -WN
0.2... 4 bar pressure range		C20-0 . . . . -WB
0.5...17 bar pressure range		C20-0 . . . . -WD
semiautomatic drain	RK500SY, max. 12 bar	C20-0 . . . . -WM
automatic drain	SA605MD, max. 12 bar	C20-0 . . . . -WR

**Accessories, enclosed**

mounting bracket	mounting at the spring cage	BW45-02	B*
mounting nut	made of aluminium	M45x1,5A	B*
mounting bracket set	made of steel, consisting of two mounting brackets	MK20-0100	
porting block	tap G¼, for unlubricated compressed air	IK20CP	

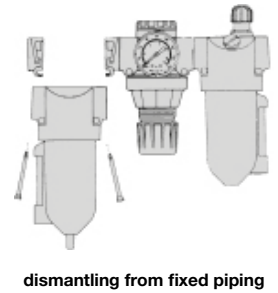
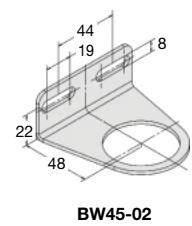
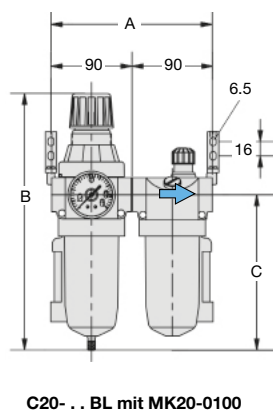
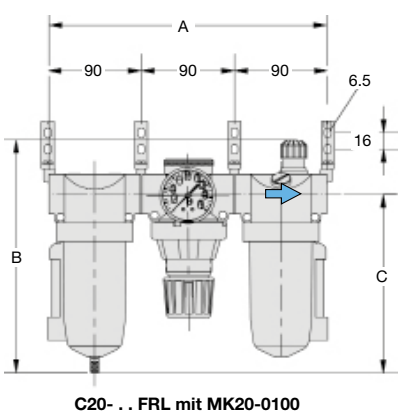

\*1 at 8 bar supply pressure, 6 bar outlet pressure and 1 bar pressure drop

\* Product group

<b>Description</b>	Solid, low-cost FRL service unit made of aluminium equipped with pressure gauge.
<b>Media</b>	compressed air or non-corrosive gases
<b>Supply pressure</b>	max. 16 bar for metal bowl with sight glass, max. 30 bar for metal bowl without sight glass
<b>Adjustment</b>	by plastic knob with snap-lock up to G $\frac{1}{2}$ by hexagon head screw from G $\frac{3}{8}$ up to G1 $\frac{1}{2}$ on (CD.-1A.) by T-handle from G1 $\frac{1}{2}$ (CD.-12.) up to G2 on
<b>Relieving function</b>	relieving, optionally non-relieving
<b>Gauge port</b>	G $\frac{1}{4}$ or G $\frac{1}{2}$ at CD.-01/-02, on both sides of the body, one screw plug supplied
<b>Filter element</b>	semiautomatic drain as standard, optionally automatic (max. 16 bar) or manual drain for max. 30 bar
<b>Drainage</b>	20 $\mu$ m or 50 $\mu$ m, optionally 5 $\mu$ m or 50 $\mu$ m, made of propylene <b>Bowl</b> metal version with or without sight glass
<b>Temperature range</b>	-10 °C to 50 °C / 14 °F to 122 °F metal bowl with sight glass, for G $\frac{1}{2}$ to G $\frac{1}{2}$ -20 °C to 60 °C / -4 °F to 140 °F metal bowl with sight glass, for G $\frac{3}{8}$ to G2 -30 °C to 80 °C / -22 °F to 176 °F metal bowl without sight glass, for all sizes
<b>Material</b>	Body: aluminium Elastomer: NBR/Buna-N Bowl: aluminium

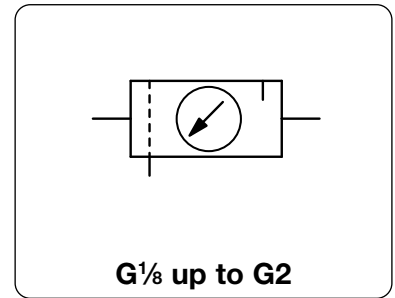

Dimensions			Combination	Bowl	Filter	Flow	Connection	Order
A	B	C	consisting	design	element	rate	thread	number
mm	mm	mm	of	made of / with		m <sup>3</sup> /h*1	G	

FRL unit, 2-part				P <sub>1</sub> : max. 16 bar, P <sub>2</sub> : 0.8...8 bar, 20 / 50 $\mu$ m, semiautomatic drain, relieving, with gauge				CD2	
80	201	128	BD+LD	metal/sight glass	50	27	450	G $\frac{1}{8}$ G $\frac{1}{4}$	<b>CD2-01</b> <b>CD2-02</b>
128	248	148		metal/sight glass	50	108	1800	G $\frac{3}{8}$ G $\frac{1}{2}$	<b>CD2-03</b> <b>CD2-04</b>
275	314	179		metal/sight glass	50	300	5000	G $\frac{3}{4}$ G1	<b>CD2-06</b> <b>CD2-08</b>
386	314	179		metal/sight glass	50	300	5000	G1 $\frac{1}{4}$ G1 $\frac{1}{2}$	<b>CD2-10</b> <b>CD2-1A</b>
355	483	223		metal/sight glass	50	960	16000	G1 $\frac{1}{2}$ G2	<b>CD2-12</b> <b>CD2-16</b>



### Special options, add the appropriate letter

<b>5 <math>\mu</math>m filter element</b>		CD2-...G
<b>0.3...3 bar regulation range</b>		CD2-...B
<b>1 ...15 bar operating press. 30 bar manual drain</b>	only for metal bowl (without sight glass) with manual drain max. 16 bar	CD2-...E CD2-...NH
<b>automatic drain</b>	drainage by float valve, max. 16 bar for G $\frac{3}{8}$ up to G2	CD2-...H CD2-...R

### Accessories, enclosed

<b>mounting bracket</b>	made of steel	for G $\frac{1}{8}$ and G $\frac{1}{4}$	<b>BW30-02</b>
<b>mounting nut</b>	made of plastic	for G $\frac{1}{8}$ and G $\frac{1}{4}$	<b>M30x1,5K</b>
<b>mounting bracket</b>	made of steel	for G $\frac{3}{8}$ and G $\frac{1}{2}$	<b>BW50-03</b>
<b>mounting nut</b>	made of plastic	for G $\frac{3}{8}$ and G $\frac{1}{2}$	<b>M50x1,5K</b>
<b>mounting bracket</b>	made of stainless steel	for G $\frac{3}{4}$ up to G1 $\frac{1}{2}$ (1A)	<b>BW00-59S</b>
<b>set of brackets</b>	made of steel	for G1 $\frac{1}{2}$ (12) and G2	<b>BW00-61</b>

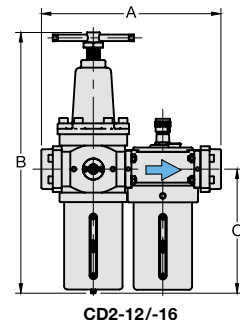
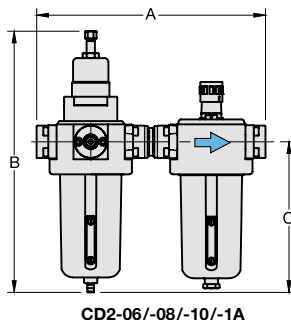
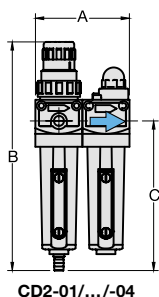

\*1 at 8 bar supply pressure, 6 bar outlet pressure and 1 bar pressure drop

Further details: see chapter for single devices

PDF CAD  
www.aircom.net

\* Product group



Order example:  
**CD2-01**



<b>Description</b>	Solid, low-cost FRL service unit made of aluminium equipped with pressure gauge.
<b>Media</b>	compressed air or non-corrosive gases
<b>Supply pressure</b>	max. 16 bar for metal bowl with sight glass, max. 30 bar for metal bowl without sight glass
<b>Adjustment</b>	by plastic knob with snap-lock up to G $\frac{1}{2}$ by hexagon head screw from G $\frac{3}{8}$ up to G1 $\frac{1}{2}$ on (CD.-1A.) by T-handle from G1 $\frac{1}{2}$ (CD.-12.) up to G2 on
<b>Relieving function</b>	relieving, optionally non-relieving
<b>Gauge port</b>	G $\frac{1}{4}$ or G $\frac{1}{2}$ at CD.-01/-02, on both sides of the body, one screw plug supplied
<b>Filter element</b>	20 $\mu$ m or 50 $\mu$ m, optionally 5 $\mu$ m or 50 $\mu$ m, made of propylene
<b>Drainage</b>	semiautomatic drain as standard, optionally automatic (max. 16 bar) or manual drain for max. 30 bar
<b>Temperature range</b>	-10 °C to 50 °C / 14 °F to 122 °F metal bowl with sight glass, for G $\frac{1}{2}$ to G $\frac{1}{2}$ -20 °C to 60 °C / -4 °F to 140 °F metal bowl with sight glass, for G $\frac{3}{8}$ to G2 -30 °C to 80 °C / -22 °F to 176 °F metal bowl without sight glass, for all sizes
<b>Material</b>	Body: aluminium Elastomer: NBR/Buna-N Bowl: aluminium

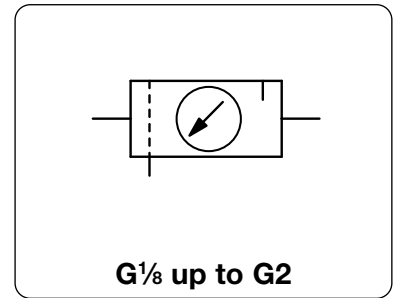

Dimensions			Combination	Bowl	Filter	Flow	Connection	Order
A	B	C	consisting	design	element	rate	thread	number
mm	mm	mm	of	made of / with		m <sup>3</sup> /h*1	G	

FRL unit, 3-part				P <sub>1</sub> : max. 16 bar, P <sub>2</sub> : 0.8...8 bar, 20 / 50 $\mu$ m, semiautomatic drain, relieving, with gauge			CD3		
120	201	128	FD+RD+LD	metal/sight glass	50	24	400	G $\frac{1}{8}$ G $\frac{1}{4}$	CD3-01 CD3-02
192	251	148		metal/sight glass	50	108	1800	G $\frac{3}{8}$ G $\frac{1}{2}$	CD3-03 CD3-04
427	312	179		metal/sight glass	50	228	3800	G $\frac{3}{4}$ G1	CD3-06 CD3-08
531	312	179		metal/sight glass	50	228	3800	G1 $\frac{1}{4}$ G1 $\frac{1}{2}$	CD3-10 CD3-1A
472	399	231		metal/sight glass	50	1320	22000	G1 $\frac{1}{2}$ G2	CD3-12 CD3-16



### Special options, add the appropriate letter

5 $\mu$ m filter element		CD3-...G
0.3...3 bar regulation range		CD3-...B
1...15 bar		CD3-...E
operating press. 30 bar	only for metal bowl (without sight glass) with manual drain	CD3-...NH
manual drain	max. 16 bar	CD3-...H
automatic drain	drainage by float valve, max. 16 bar for G $\frac{3}{8}$ up to G2	CD3-...R

### Accessories, enclosed

mounting bracket	made of steel	for G $\frac{1}{8}$ and G $\frac{1}{4}$	<b>BW30-02</b>
mounting nut	made of plastic	for G $\frac{1}{8}$ and G $\frac{1}{4}$	<b>M30x1,5K</b>
mounting bracket	made of steel	for G $\frac{3}{8}$ and G $\frac{1}{2}$	<b>BW50-03</b>
mounting nut	made of plastic	for G $\frac{3}{8}$ and G $\frac{1}{2}$	<b>M50x1,5K</b>
mounting bracket	made of stainless steel	for G $\frac{3}{4}$ up to G1 $\frac{1}{2}$ (1A)	<b>BW00-59S</b>
set of brackets	made of steel	for G1 $\frac{1}{2}$ (12) and G2	<b>BW00-61</b>

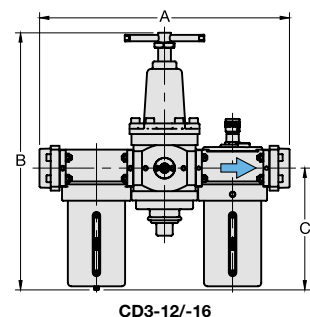
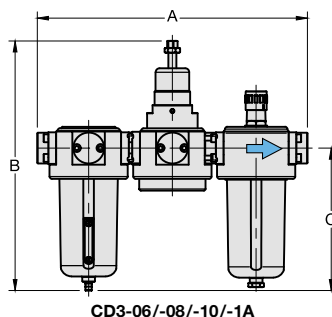
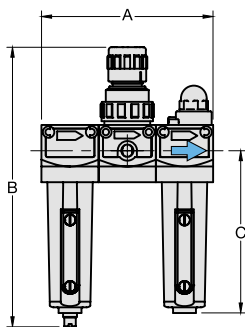

\*1 at 8 bar supply pressure, 6 bar outlet pressure and 1 bar pressure drop

\* Product group

Further details: see chapter for single devices

PDF CAD  
www.aircom.net



Order example:  
CD3-01



<b>Description</b>	FRL service unit of small size and with high flow. Compact design, proven in operation.		
<b>Media</b>	compressed air or non-corrosive gases		
<b>Supply pressure</b>	max. 17 bar for metal bowl with sight glass		
<b>Adjustment</b>	by T-handle with locknut,	by plastic knob with snap-lock on pilot regulator at size G2	
<b>Relieving function</b>	relieving, optionally non-relieving	<b>Air consumption</b> only for pilot pressure at size G2	
<b>Gauge port</b>	G $\frac{1}{4}$ on both sides of the body, one screw plug supplied		
<b>Filter element</b>	40 $\mu$ m, optionally 5 $\mu$ m, made of polypropylene		
<b>Bowl</b>	metal version with sight glass		
<b>Drainage</b>	manual drain as standard	for max. 21 bar	
	optionally internal automatic drain	for max. 12 / 16 bar	
	or external automatic drain	for max. 18 bar	
<b>Temperature range</b>	0 °C to 70 °C / 32 °F to 158 °F for metal bowl with sight glass		
<b>Material</b>	Body: zinc die-cast	Elastomer: NBR/Buna-N	
	Bowl: polyurethane, zinc die-cast or steel	Inner valve: brass	

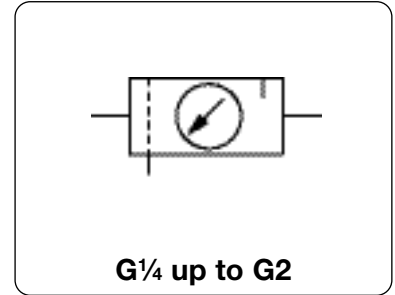

Dimensions			Combination consisting of	Bowl design made of/with	Flow rate		Connection thread G	Order number
A	B	C			m <sup>3</sup> /h*1	l/min*1		

FRL unit, 3-part				P: max. 17 bar, P <sub>2</sub> : 0.3...9 bar, 40 $\mu$ m, manual drain, relieving, with pressure gauge		C630		
400	267	197	F602 + R119, + L606	metal/sight glass	408	6 800	G $\frac{3}{4}$	C630-06FRL-W
					516	8 600	G1	C630-08FRL-W
419	286	206		metal/sight glass	600	10 000	G1 $\frac{1}{4}$	C630-10FRL-W
					630	10 500	G1 $\frac{1}{2}$	C630-12FRL-W
485	425	356		metal/sight glass	1 590	26 500	G2	C630-16FRL-W



### Special options, add the appropriate letter

5 $\mu$ m filter element		C630-0 . . . . . G
NPT connection thread		C630-0 . . . . . N
0.2... 4 bar pressure range		C630-0 . . . . . B
0.5...17 bar pressure range		C630-0 . . . . . D
semiautomatic drain	RK500SY, max. 12 bar	C630-0 . . . . . M
automatic drain	SA605MD, max. 12 bar	C630-0 . . . . . R
flange connection	see chapter for stainless steel devices / flanges	C630-0 . . . . . F



### Accessories, enclosed

mounting bracket	made of steel	for G $\frac{3}{4}$ to G1 $\frac{1}{2}$	<b>BW00-24</b>
------------------	---------------	---	----------------

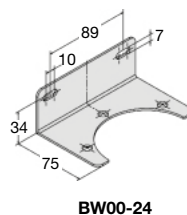
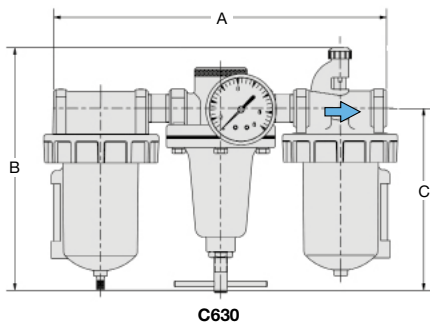

\*1 at 8 bar supply pressure, 6 bar outlet pressure and 1 bar pressure drop

\* Product group

Further details: see chapter for single devices

PDF CAD  
www.aircom.net



Order example:  
C630-06FRL-A

<b>Manual drain</b>	The manual drain can be opened by screwing it into the bowl. Once the collected condensate reaches the drain hole, it is being relieved.
<b>Semiautomatic drain</b>	The semiautomatic drain semiautomatically separates condensates from compressed air or gas systems. After operating pressure switch-off the drain valve opens and the collected condensate is being relieved.
<b>Automatic drain</b>	The automatic drain fully automatically separates condensates from compressed air or gas systems. Once the float lifts from the valve seat caused by the condensate level, the condensate is being relieved. Operating pressure must be 2 bar minimum.
<b>Temperature range</b>	0 °C to 50 °C / 32 °F to 122 °F 0 °C to 80 °C / 32 °F to 176 °F for manual drain made of brass for appropriately conditioned compressed air down to -30 °C / -22 °F

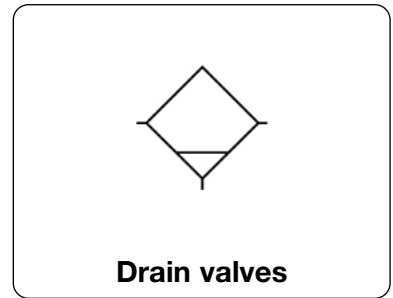

Valve type	Description	For filter/ filter regulator	For bowl type	Operating pressure max. bar	Order number	B*
------------	-------------	---------------------------------	------------------	-----------------------------------	-----------------	----

Drain valves		1/8"-27 NPSM thread of internal valve			SA/RK
<b>manual drain</b>	made of brass	F20/ F504/F602 / B11/B12/B20/B21/ B548	all	21	<b>SA600Y-71</b>
	made of plastic	F20/ F504/F602/ B11/B12/B20/B21/ B548	all	21	<b>AWF-10</b>
<b>semiautomatic drain</b>	piston drain	F504	all	12	<b>RK504SY</b>
	drainage after pressure switch-off	F602-02/-03	A/B/W	12	<b>RK602SY</b>
		B11/B12	all	12	<b>4210</b>
	spring-loaded	F20/ F20/ F504/F602/ B11/B12/B20/B21/ B548	all	12	<b>4212</b> <b>RK504SY</b> <b>RK500SY</b>
<b>automatic drain</b>	internal mounting effective from 2 bar on	F20/F602/B11/ B12/B20/B21/ F20/F602/ B20/B21	all	12	<b>SA605MD</b>
		F20/F602/ B20/B21	all	16	<b>SA702MD</b>
	external mounting	F602-04 to -20 F602-04 to -20	A/B/W E/F	18 18	<b>SA602D</b> <b>SA603D</b>



Drain valves made of SST		1/8"-27 NPSM valve thread			SA
<b>automatic drain</b>	internal mounting effective from 2 bar on	F10/F11/B11-S	all	12	<b>SA10MDSS</b>



\* Product group

PDF CAD  
www.aircom.net



Order example:  
**SA600Y-71**

**Description** Air supply is immediately shut off when volume flow exceeds a specific value. The maximum admissible flow is factory-set in such a way that a standard application of pneumatic equipment is ensured. Pressure drop amounts to 0.05 to 0.3 bar. In the case of failure, the hose rupture valve blows off through a small nozzle. After repairing the hose break, the hose rupture valve can be set to zero again.

**EN ISO 4414-11.2010** According to EN ISO 4414-11.2010 the hose rupture valve protects individuals, systems and machines from injuries or damages caused by lashing hose lines in the event of hose breaks.

**Function** The air passes the piston and continues through the seat. The air stream is slowed down by means of lengthwise grooves on the piston surface. When the volume flow is too high, the air cannot pass the piston quickly enough, thus the piston will be pressed against the spring. If the maximum admissible flow is exceeded, e.g. when the hose suddenly breaks, the air supply will automatically be shut off.

**Supply pressure** max. 18 bar  
**Temperature range** -20 °C to 80 °C / -4 °F to 176 °F at G¼ to G½, up to 120 °C / 248 °F at G¾ to G2  
**Material** Body: aluminium, optionally stainless steel Elastomer: NBR/Buna-N  
 Inner valve: aluminium and plastic



**max. 18 bar**  
**G¼ up to G2**

Dimensions			max. flow rate		Connection thread	Order number
B	C	A/F	at 8 bar *2			
mm	mm	mm	m³/h	l/min	G	

Hose Rupture Valve "HoseGuard®"						operating pressure max. 18 bar	281
49	-	22	46	760 *1	G¼	281A0211	
49	10	22	46	760 *1	G¼mf	281A0221	
49	-	22	3	52	G¼	281ZL0211	
49	10	22	3	52	G¼mf	281ZL0221	
49	-	22	60	990	G¼	281ZH0211	
49	10	22	60	990	G¼mf	281ZH0221	
58	-	27	65	1080 *1	G¾	281A0311	
58	12	27	65	1080 *1	G¾mf	281A0321	
58	-	27	87	1450	G¾	281ZH0311	
58	12	27	87	1450	G¾mf	281ZH0321	
65	-	30	181	3020 *1	G½	281A0411	
64	15	30	181	3020 *1	G½mf	281A0421	
65	-	30	206	3440	G½	281ZH0411	
64	15	30	206	3440	G½mf	281ZH0421	
76	-	30	244	4070 *1	G¾	281A0511	
76	-	30	315	5250	G¾	281ZH0511	
100	-	41	313	5220 *1	G1	281A0611	
100	-	41	456	7600	G1	281ZH0611	
130	-	70	775	12920 *1	G2	281A0911	



281

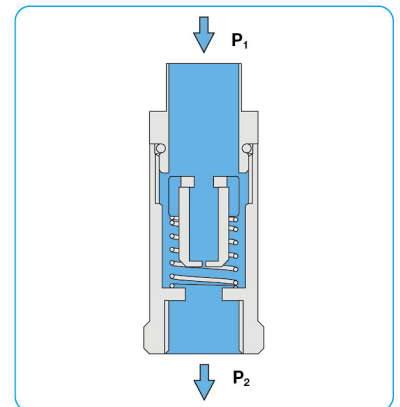

cross-section

### Special options, add the appropriate letter

- NPT** connection thread for standard version 281A1 . . .
- connection thread for Low-Flow version 281ZL1 . . .
- connection thread for High-Flow version 281ZH1 . . .
- stainless steel body** 281R . . .

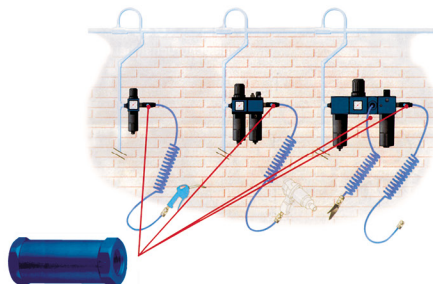
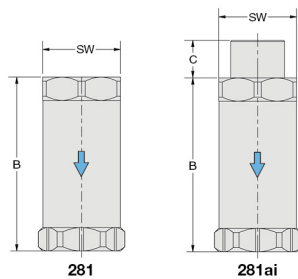

application example

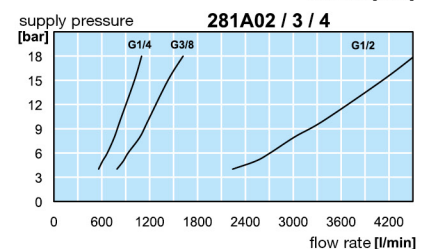
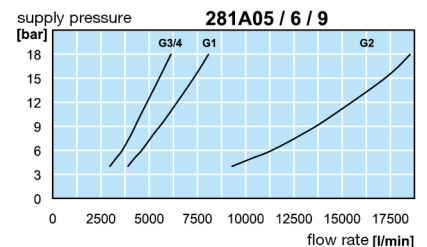

\*1 Standard version

\*2 volume flow measurement according to DIN EN60534 (± 10% for closing)

\* Product group

